

PALLET DOLLY  
Appendix C2 (Annex B)  
PD DRAWING

16/11/10

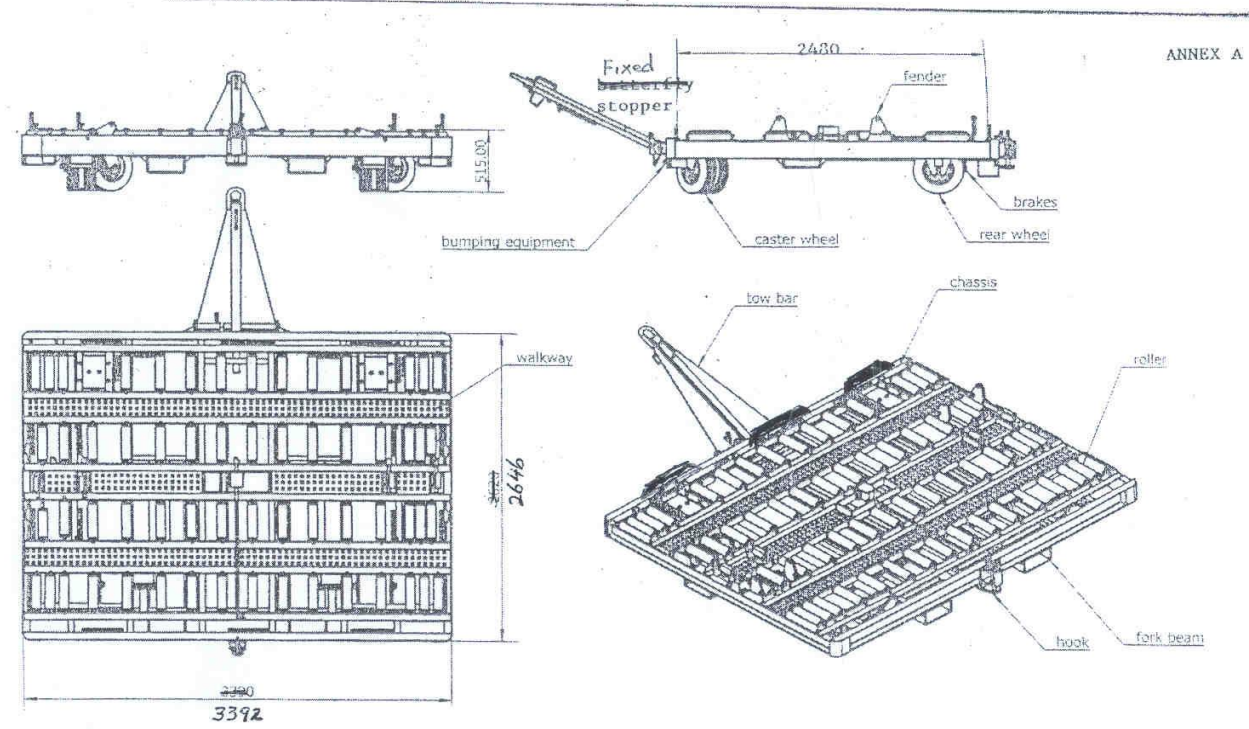

PALLET DOLLY  
Appendix C2 (Annex I)  
PD DRAWING

Annex B

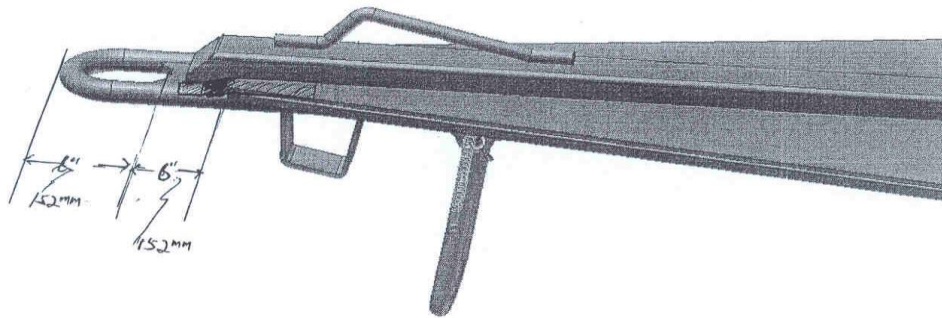

PALLET DOLLY  
Appendix C2 (Annex B)  
PD DRAWING

*Annex B.*

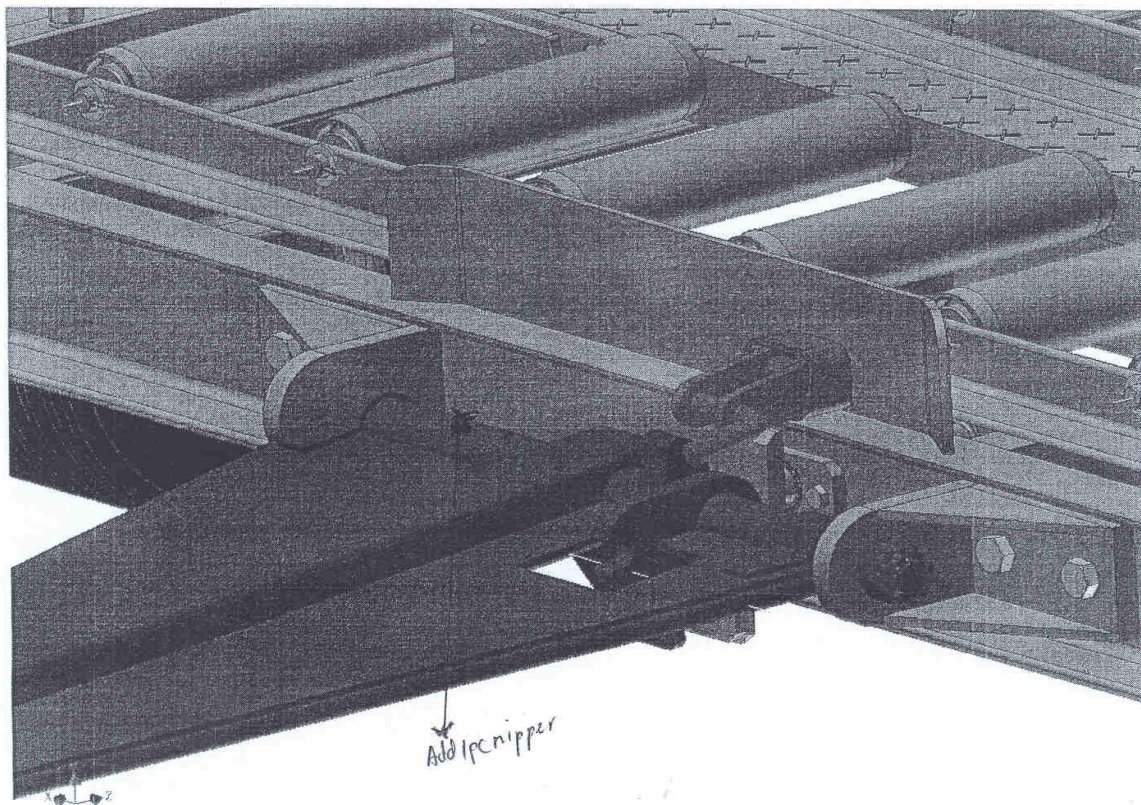



PALLET DOLLY  
Appendix C2 (Annex B)  
PD DRAWING

Annex B

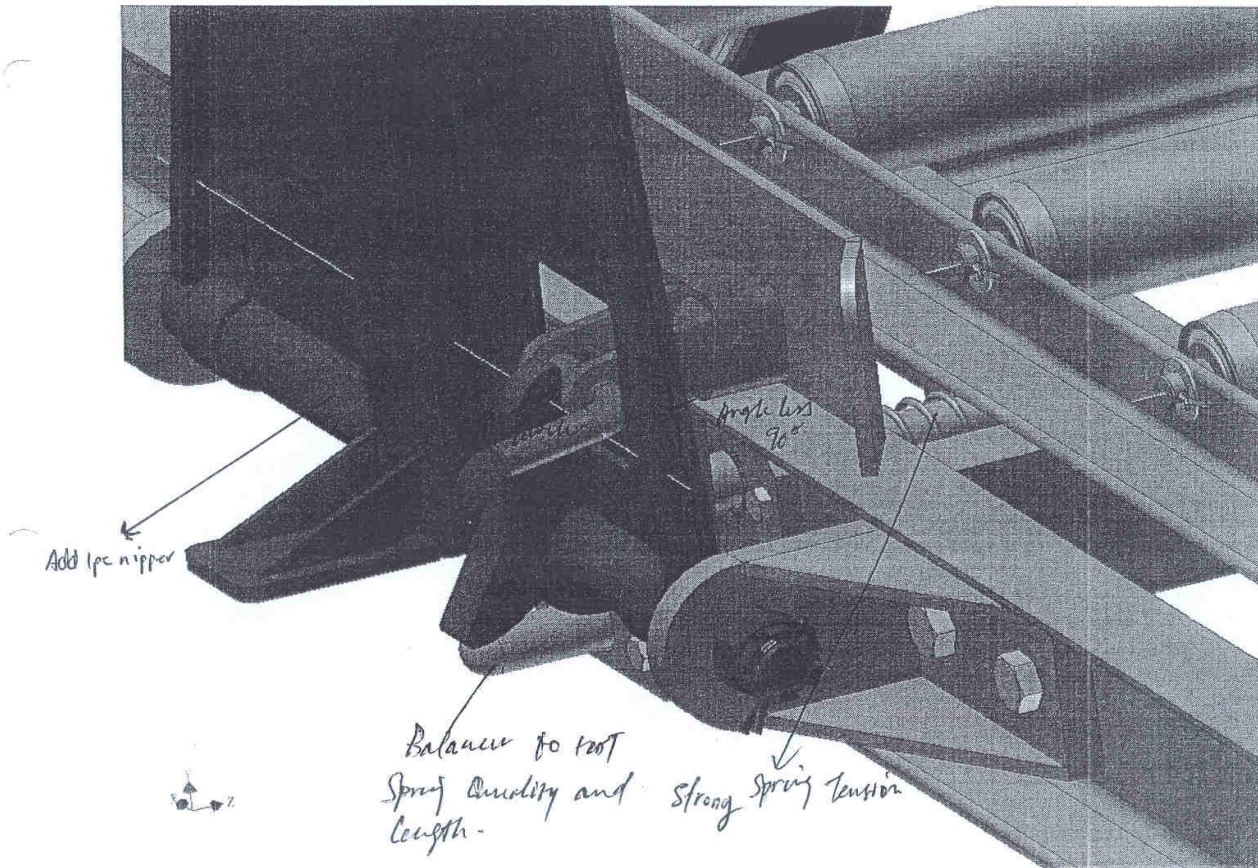

PALLET DOLLY  
Appendix C2 (Annex B)  
PD DRAWING

8.

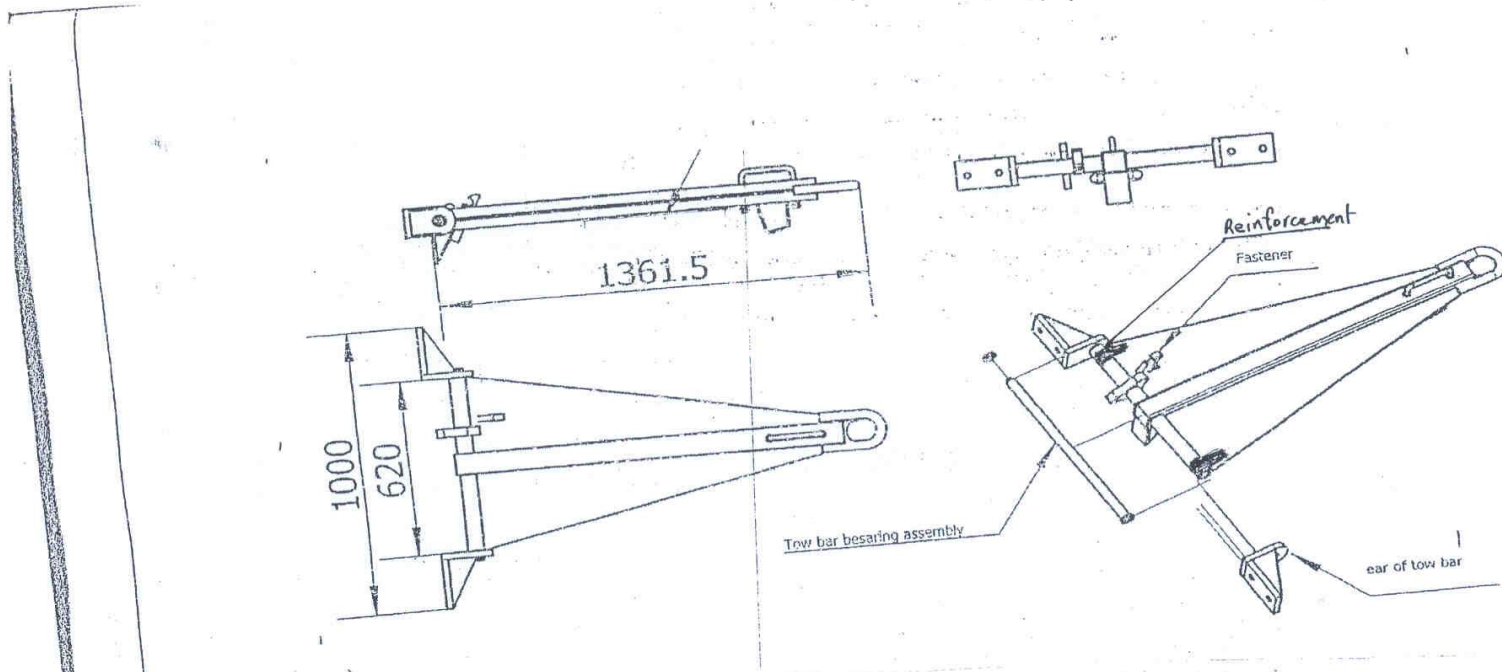

DETAILS

- 1) Tow bar ring size mild steel rod's outside diameter is 32mm;
- 2) Tow bar round pipe size (mild steel) outside diameter is 50mm and internal diameter 32mm;
- 3) Tow bar square tube size is 76mm x 76mm x 9mm for centre main structure;
- 4) Tow bar iron plate thickness (mild steel) 6mm;
- 5) Tow bar shaft size bright mild steel rod outer diameter is 32mm x 745mm;
- 6) 2 brackets (mild steel) thickness is 9mm with bolt and nut and must be welded to the pallet's body;
- 7) The length of the tow bar including tow bar's ring is 1410mm;
- 8) 2 reinforcement bars (thickness 3mm) are required to weld at two corners as shown in the picture; and
- 9) 20mm x 20mm x 3mm square tube will be used for the side structure.

PALLET DOLLY  
Appendix C2 (Annex C)  
PD DRAWING

*Annex C*

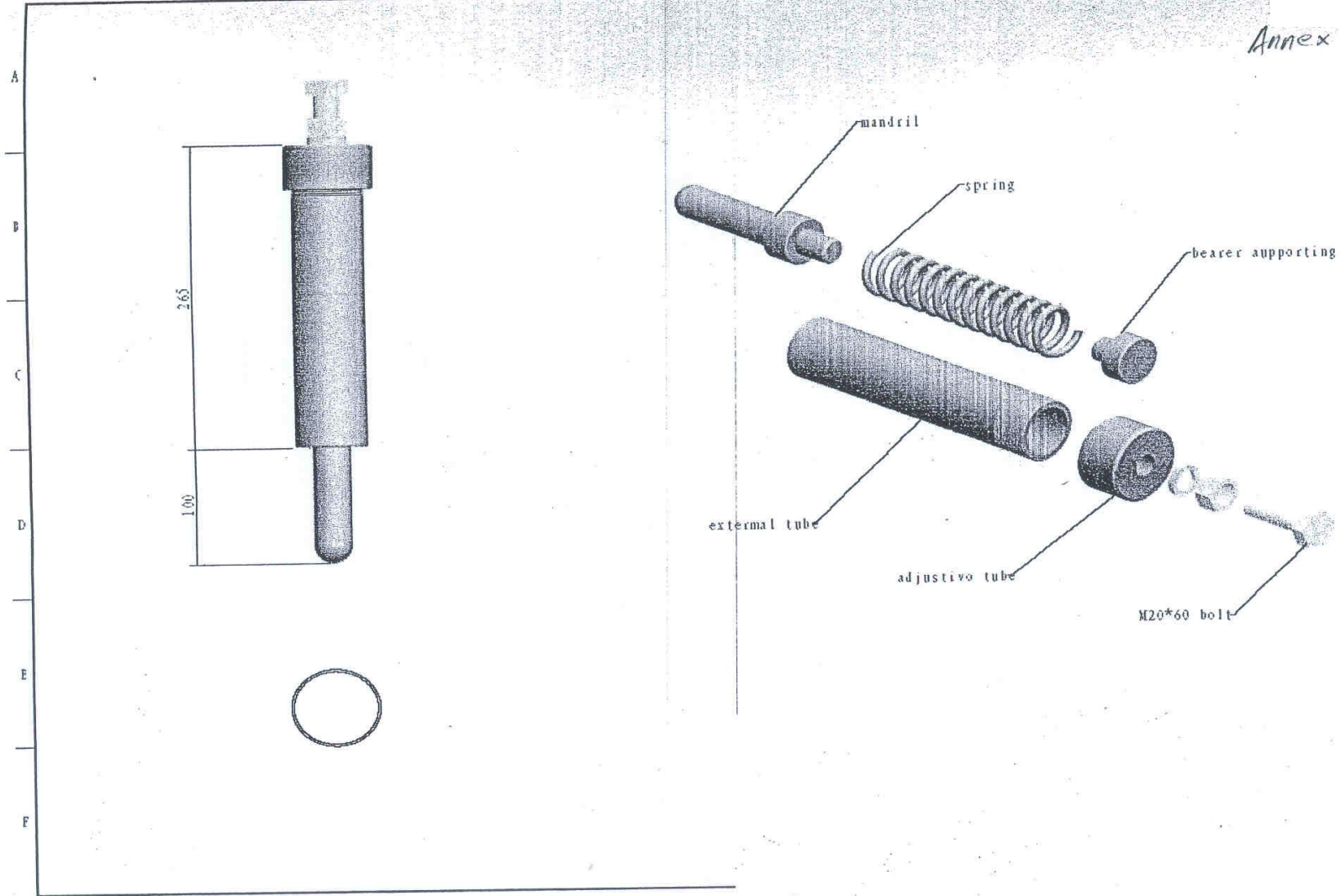

PALLET DOLLY  
Appendix C2 (Annex D)  
PD DRAWING

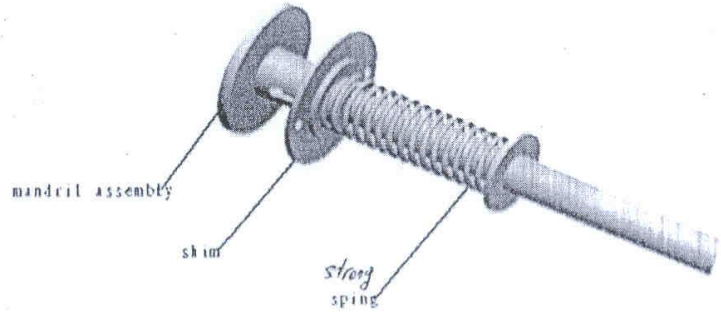
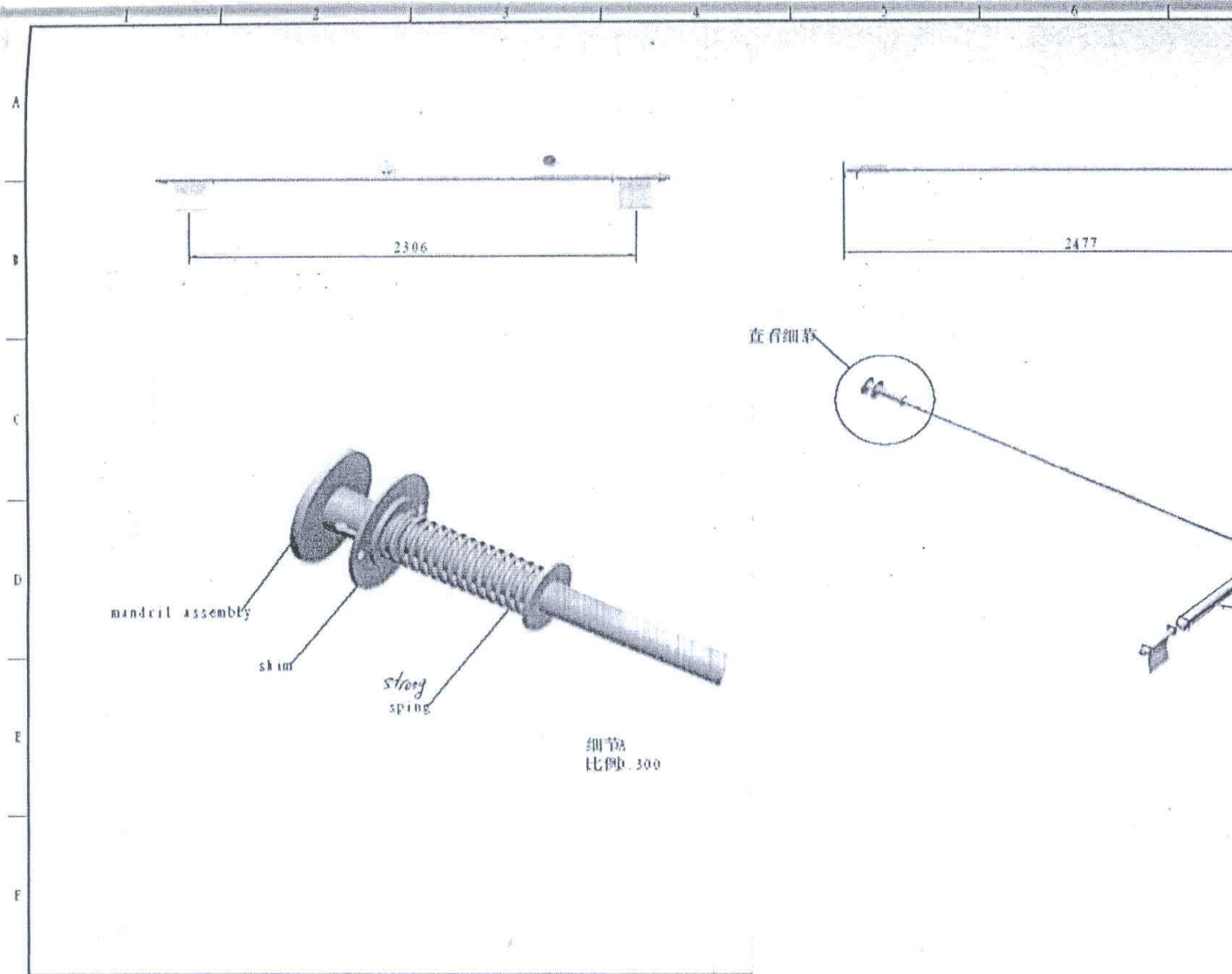

细节  
比例: 300

查看细节

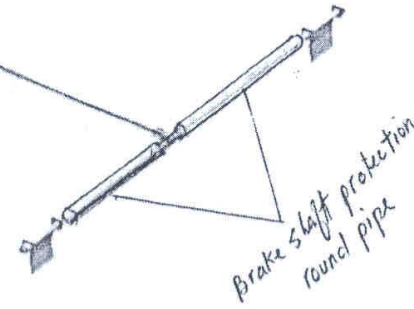



PALLET DOLLY  
Appendix C2 (Annex E)  
PD DRAWING

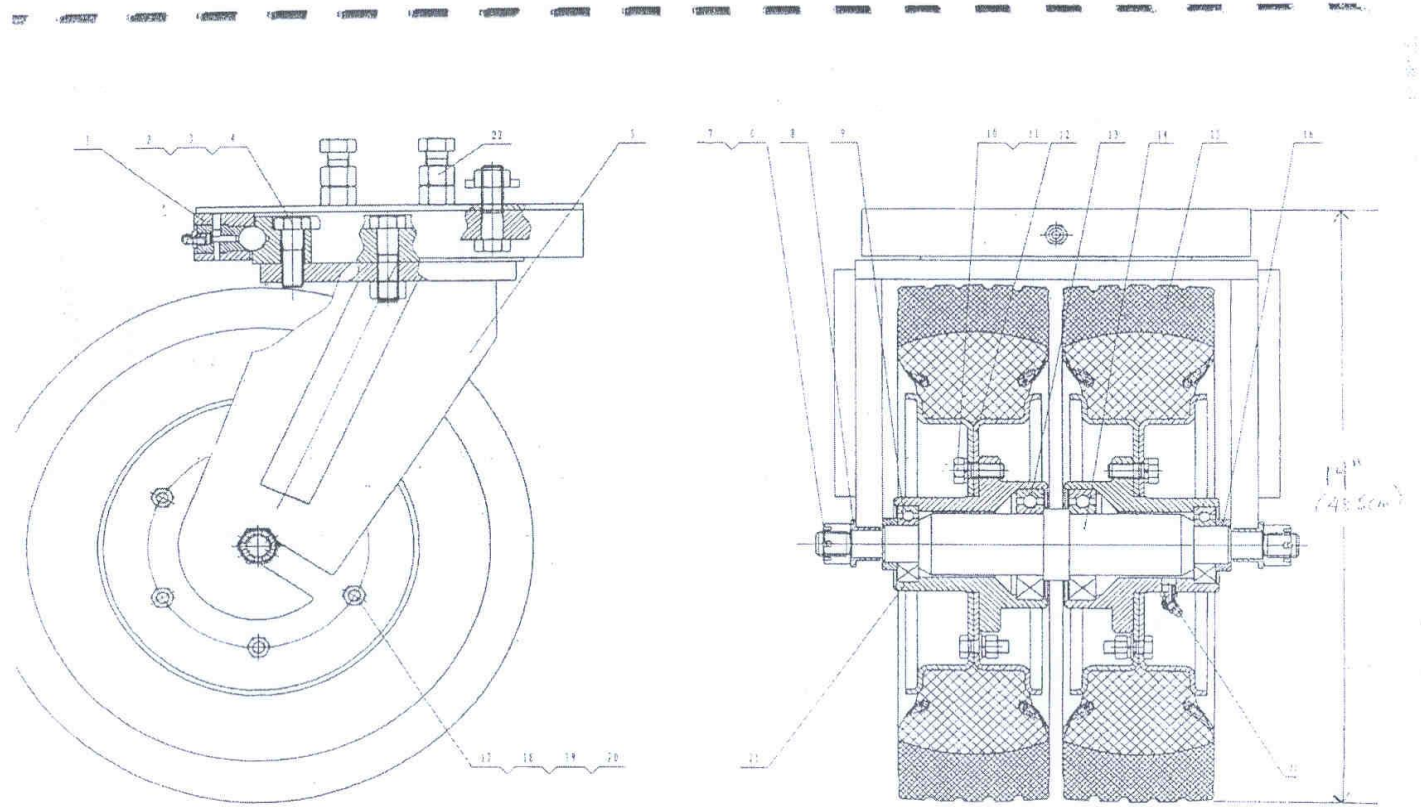



PALLET DOLLY  
Appendix C2 (Annex E)  
PD DRAWING

A

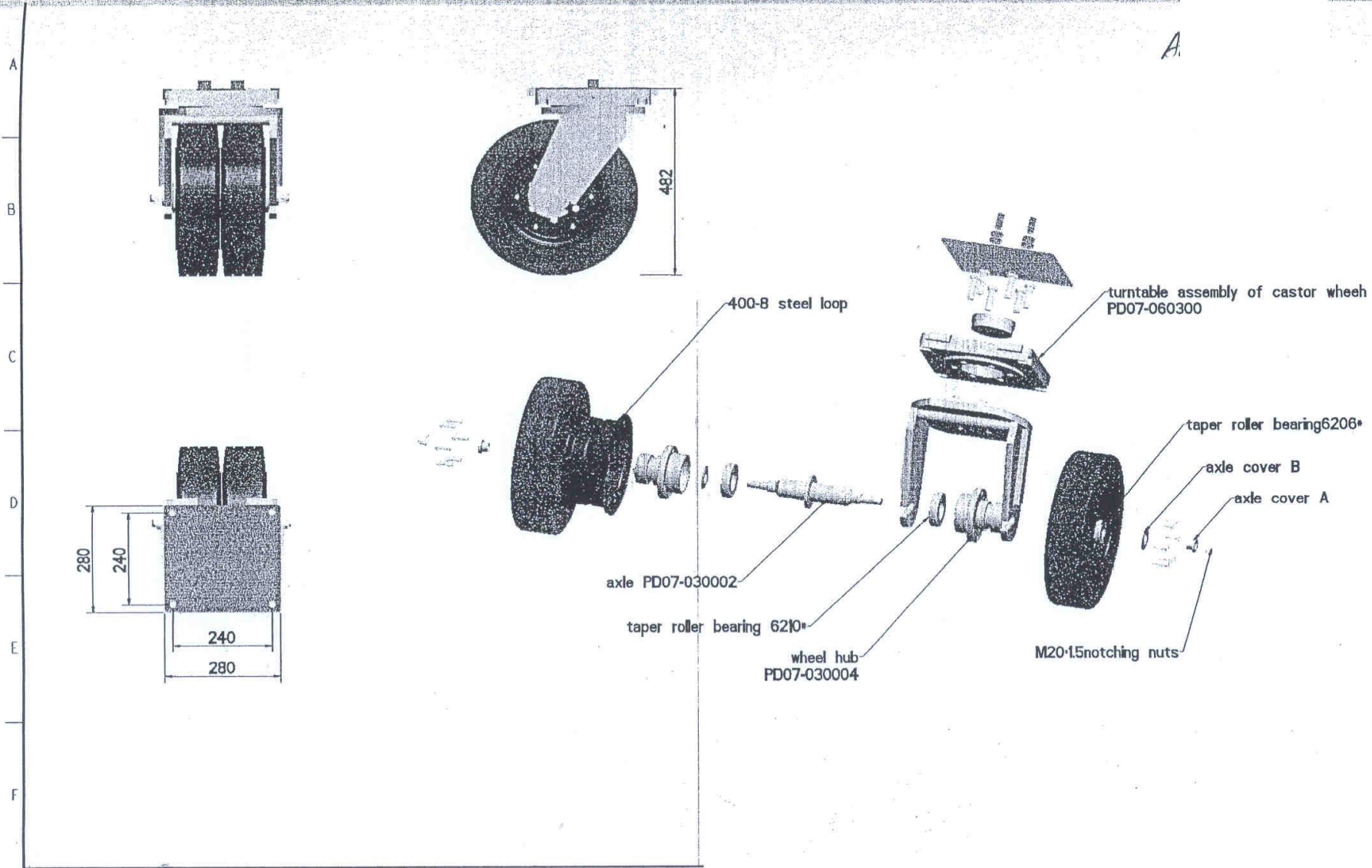

PALLET DOLLY  
Appendix C2 (Annex E)  
PD DRAWING

Annex E

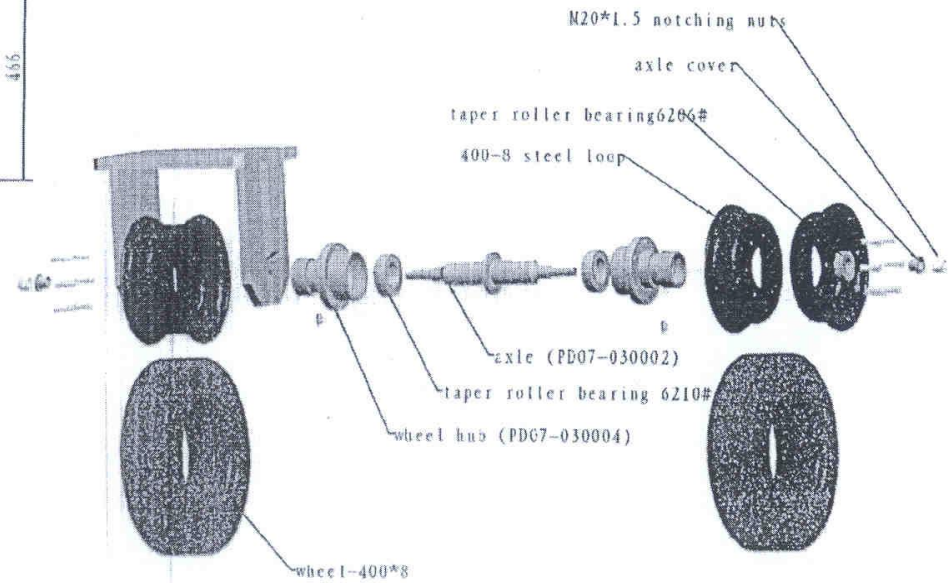
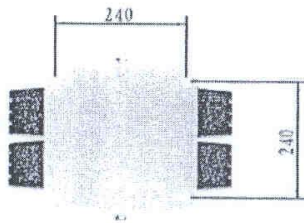
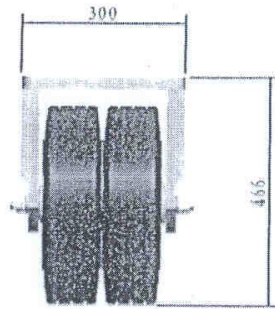
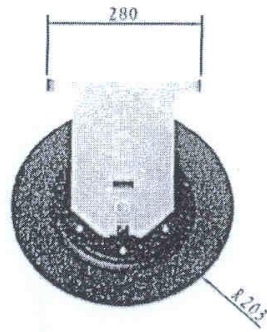

PALLET DOLLY  
Appendix C2 (Annex F)  
PD DRAWING

Annex F.

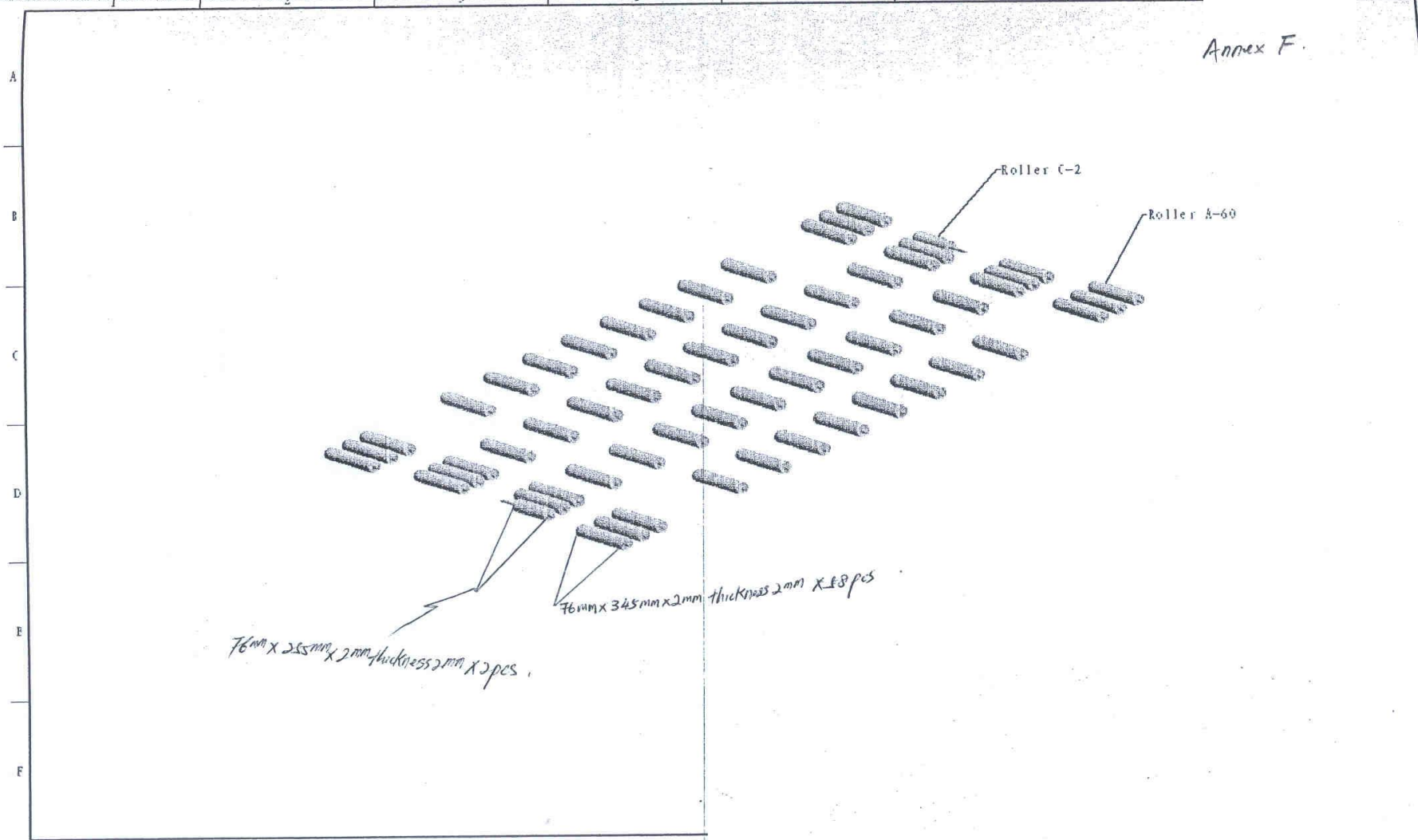

PALLET DOLLY  
Appendix C2 (Annex G)  
PD DRAWING

Annex G.

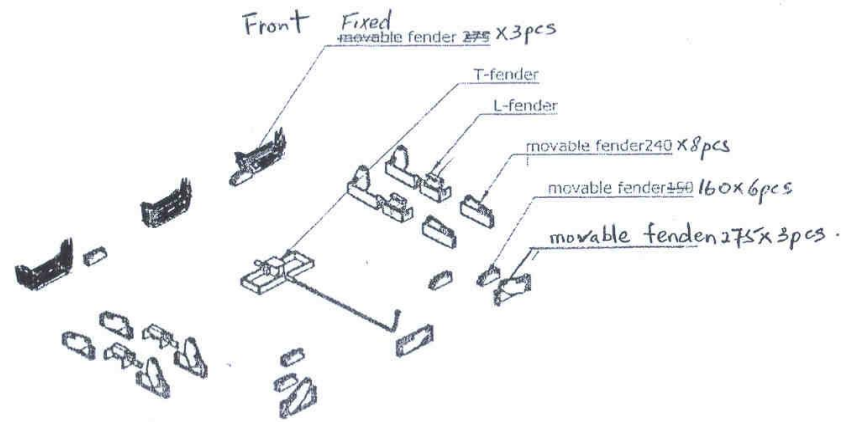
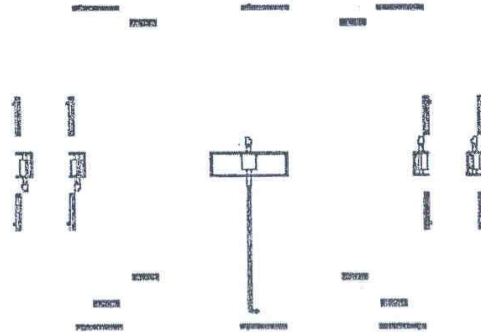
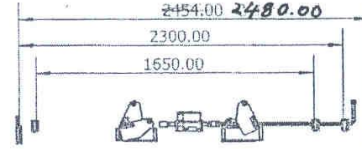
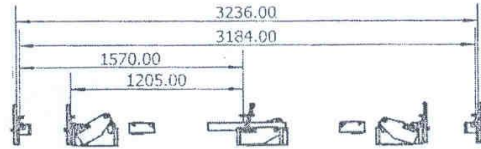



PALLET DOLLY  
Appendix C2 (Annex H)  
PD DRAWING

*Annex H*

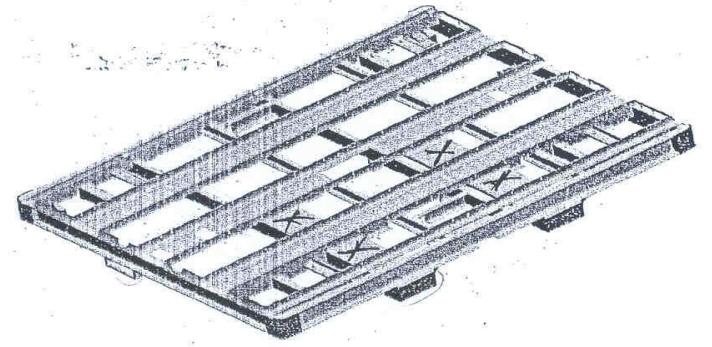
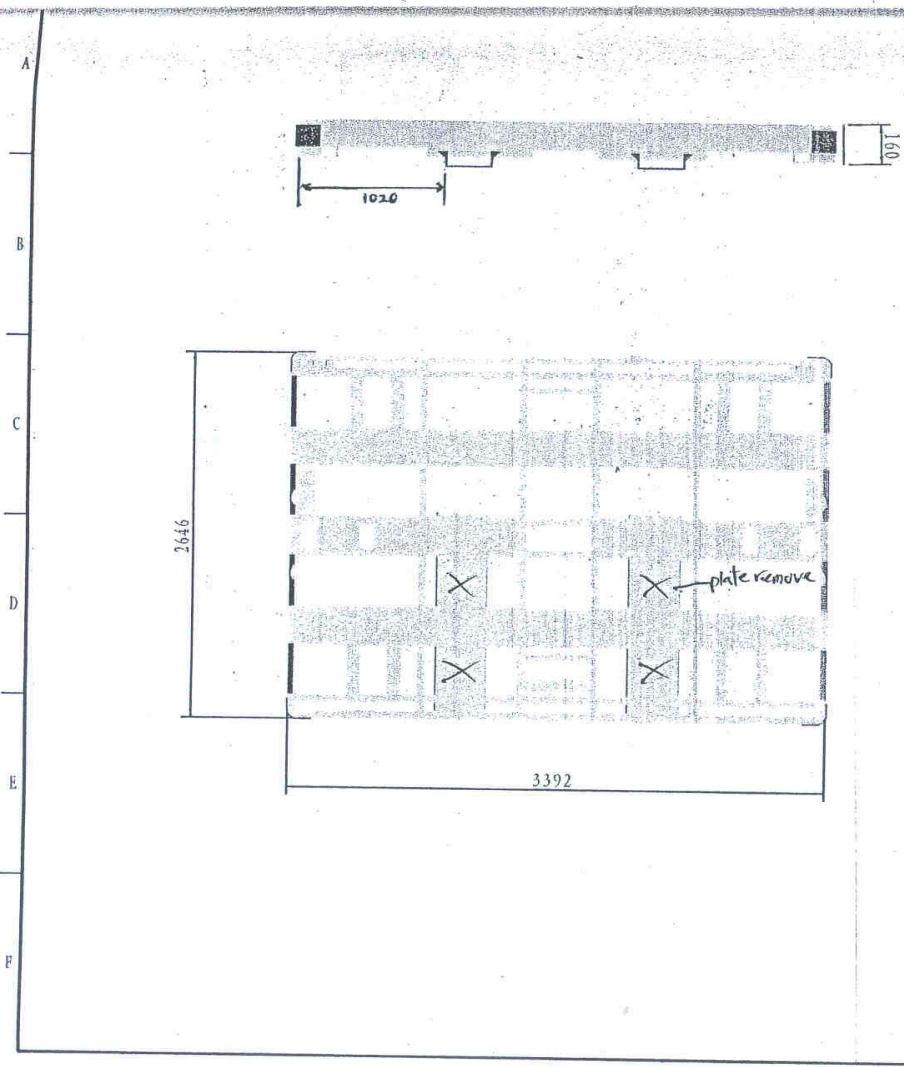

PALLET DOLLY  
Appendix C2 (Annex H)  
PD DRAWING

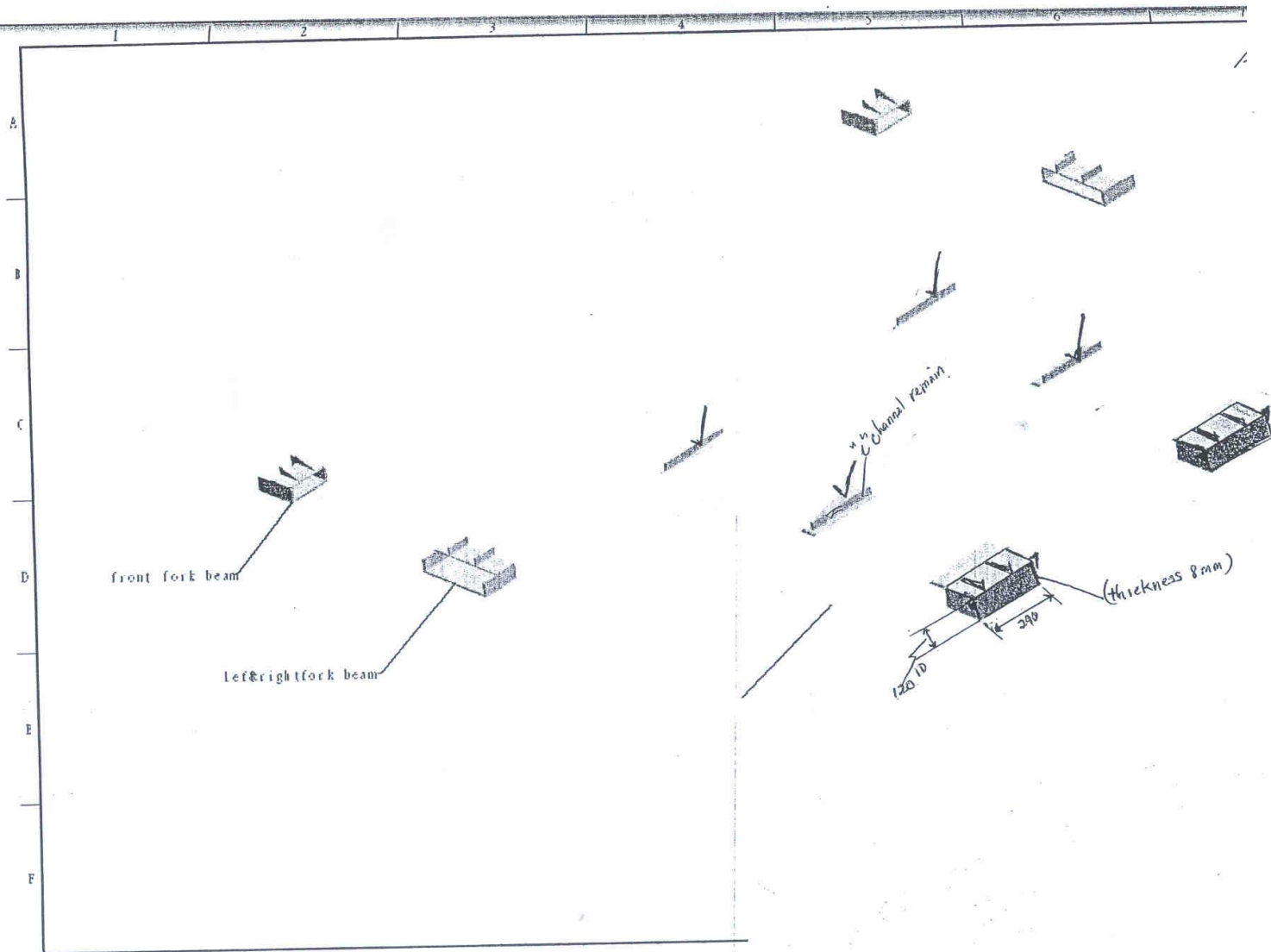

PALLET DOLLY  
Appendix C2 (Annex H)  
PD DRAWING

Annex H.

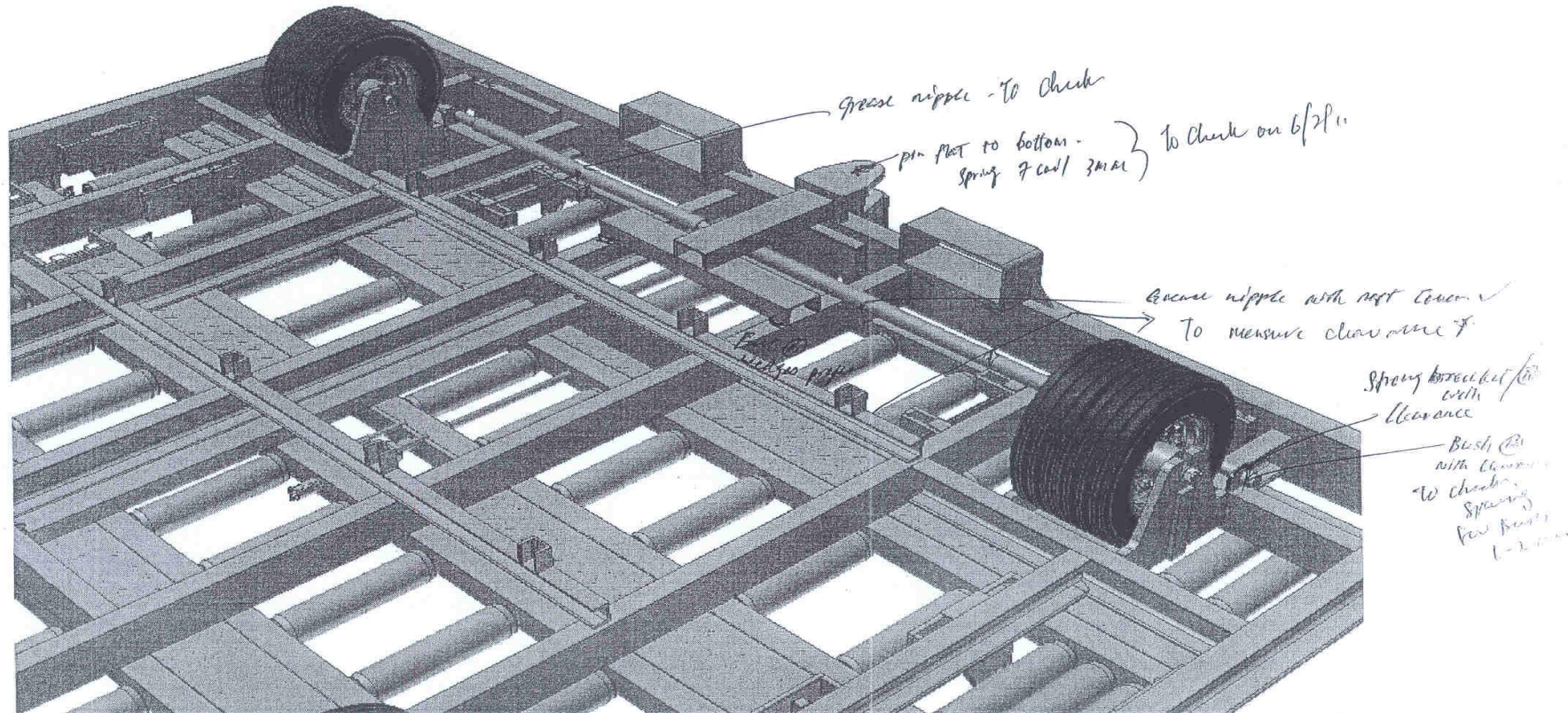



PALLET DOLLY  
Appendix C2 (Annex I)  
PD DRAWING

*Annex I*

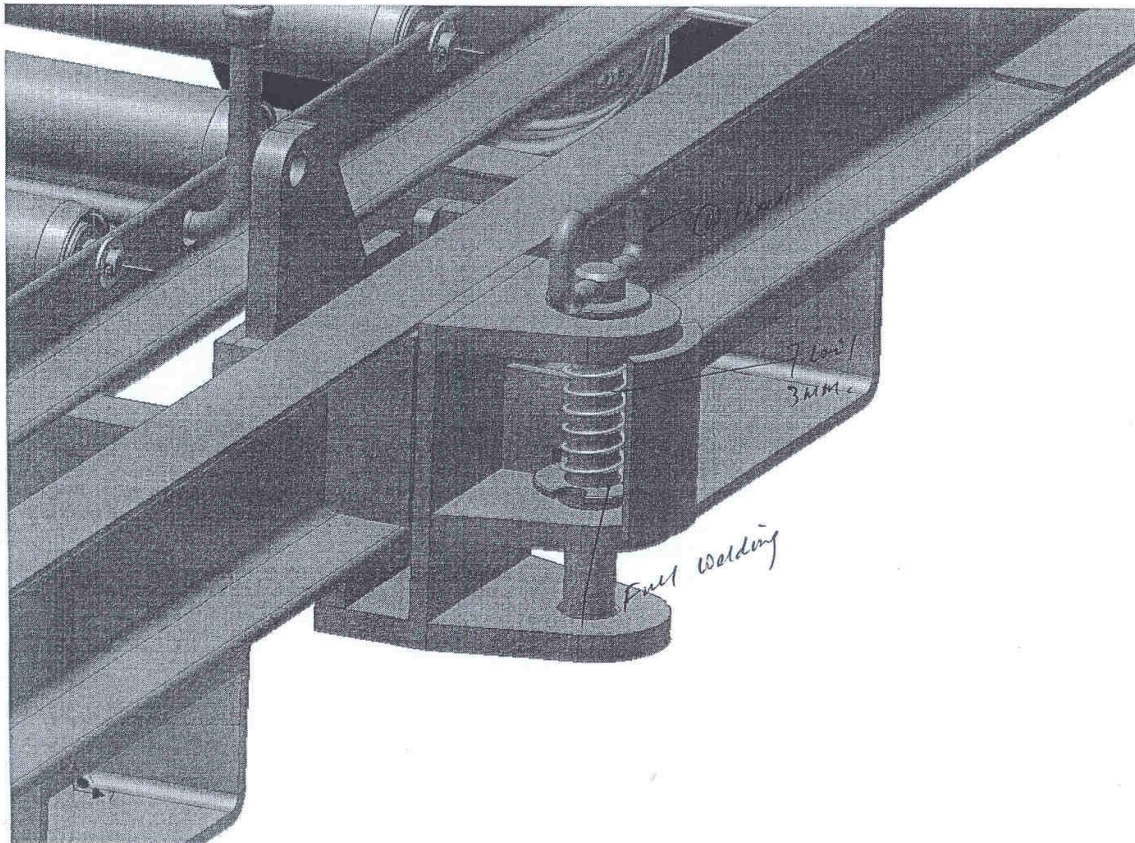



PALLET DOLLY  
Appendix C2 (Annex I)  
PD DRAWING

19/11/2011

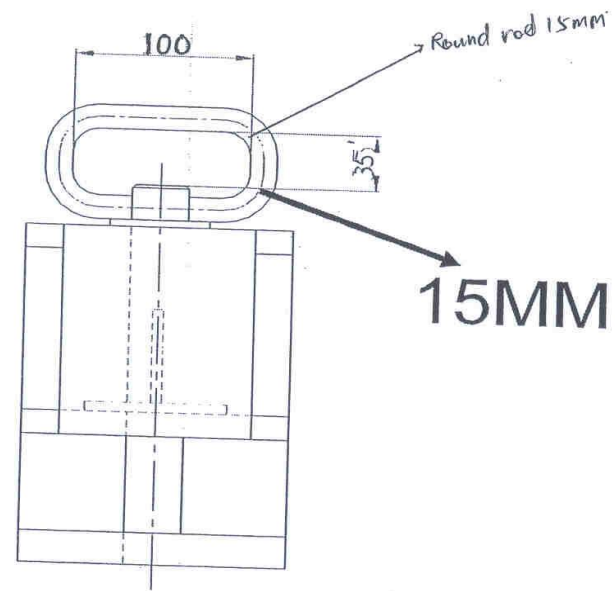
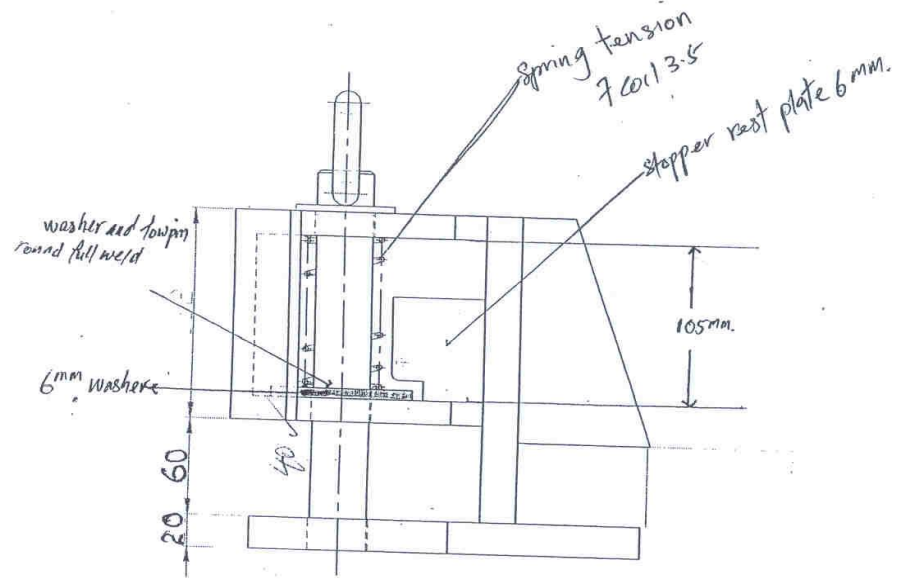

Annex I

(HANDLE)  
15MM 把手

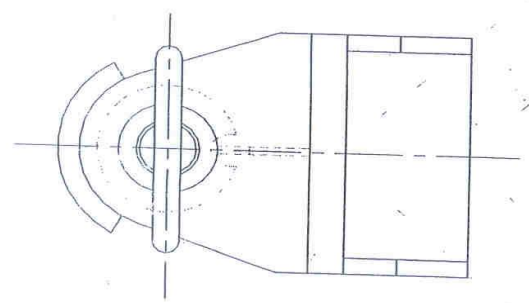

PALLET DOLLY  
Appendix C2 (Annex J)  
PD DRAWING

*Annex J*

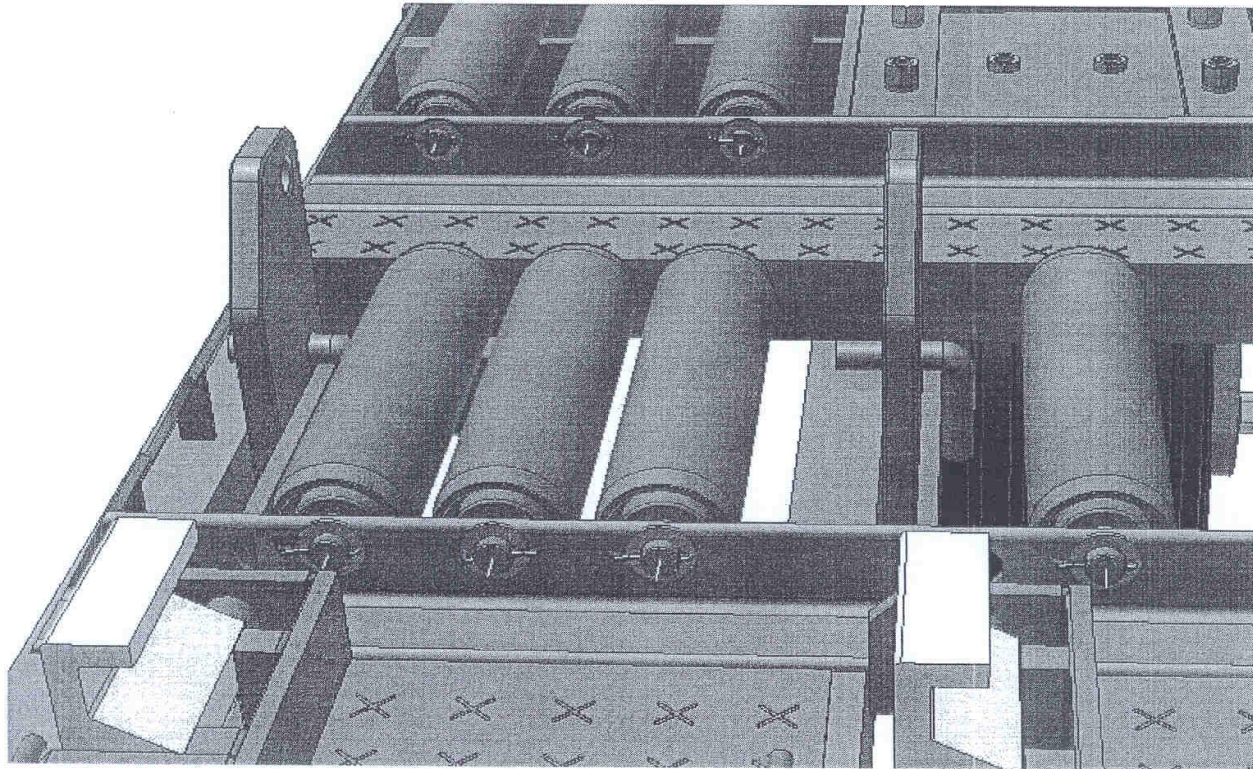



PALLET DOLLY  
Appendix C2 (Annex K)  
PD DRAWING

*Annex K.*

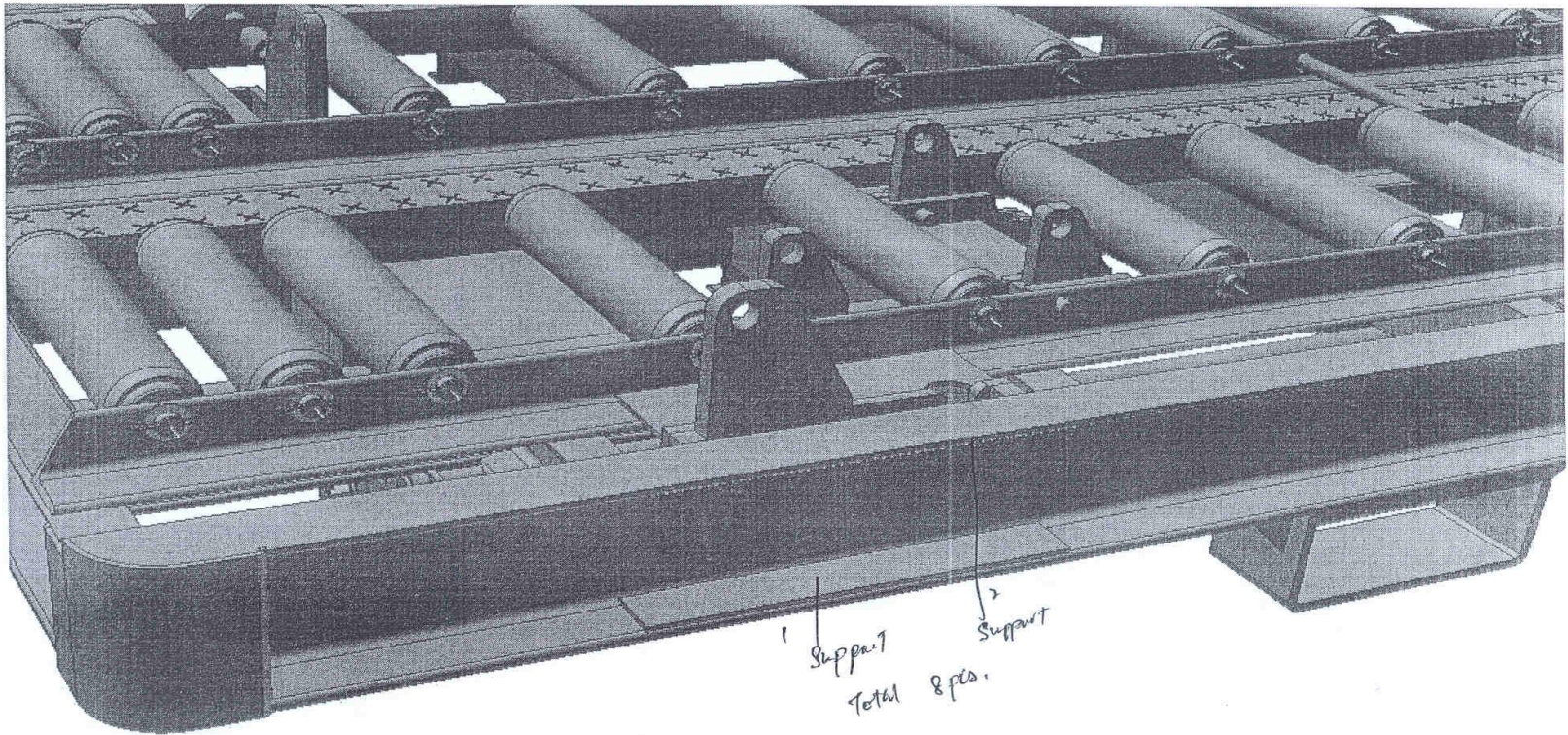



PALLET DOLLY  
Appendix C2 (Annex K)  
PD DRAWING

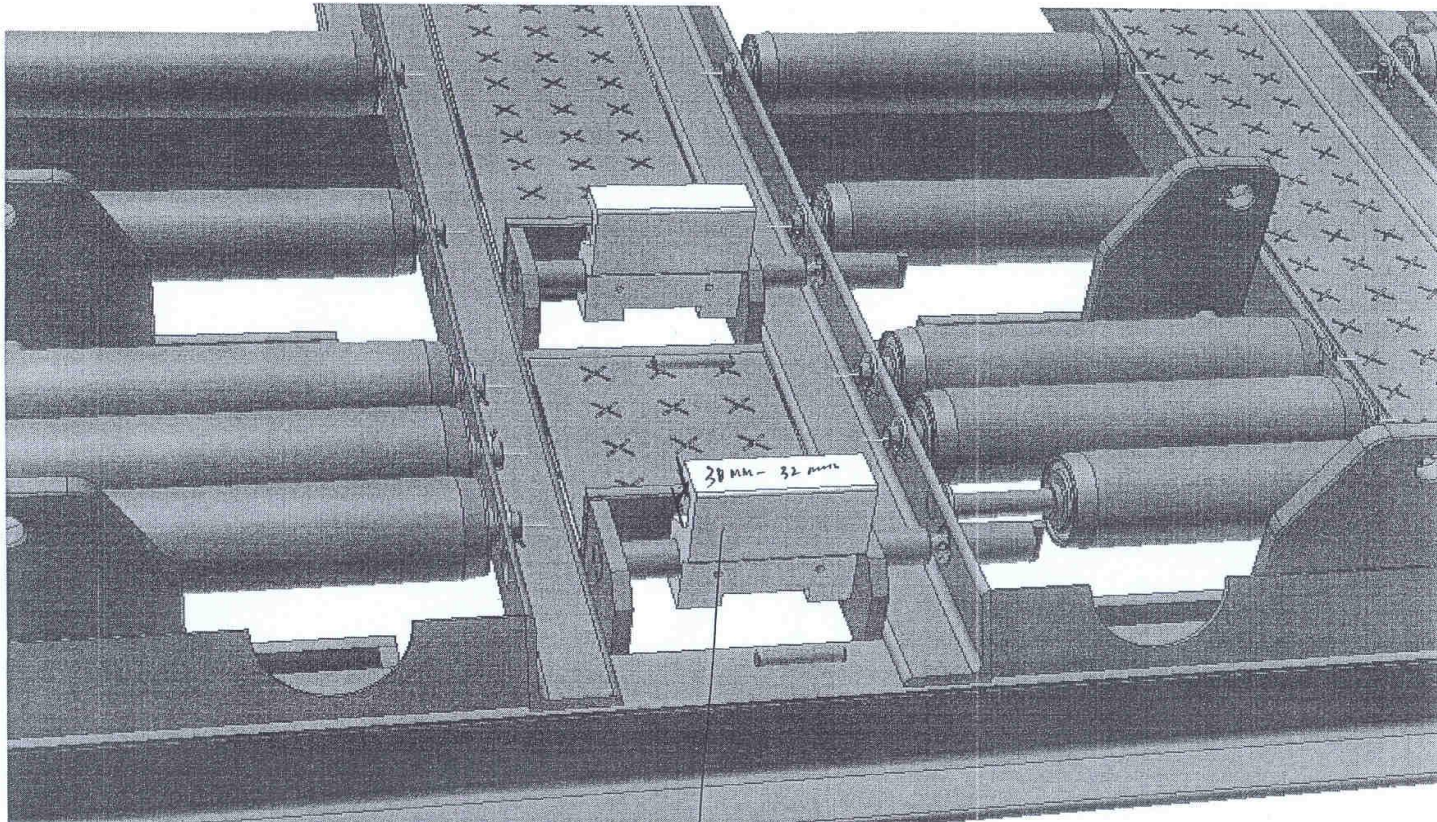

✓ Test with 1" zig.